

DN10/15 - 50

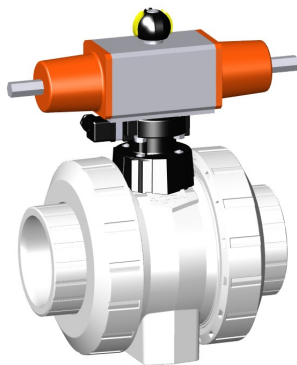

SYGEF Standard Kulový kohout typ 232 Funkce FC (Bez tlaku zavřeno) Bez ručního ovládání S nátrubky pro polyfúzní svařování metric

Provedení:

- Materiál: **PVDF**
- Řídicí čas 90°<) 1-2 s
- Přřazení pohonů: PA11 (DN10/15-25), PA21 (DN32-50), PA30 (DN65), PA40 (DN80), PA40 (DN100)
- Snadná montáž a demontáž
- Integrované nerezové montážní závit

Možnosti:

- Individuální konfigurace kulového kohoutu

d (mm)	DN (mm)	PN (bar)	kv-hodnota ($\Delta p=1$ bar) (L/min)	FKM kód	SP	Váha (kg)
16	10	10	70	199 232 132	1	1.200
20	15	10	185	199 232 133	1	1.079
25	20	10	350	199 232 134	1	1.300
32	25	10	700	199 232 135	1	1.322
40	32	10	1000	199 232 136	1	2.500
50	40	10	1600	199 232 137	1	3.216
63	50	10	3100	199 232 138	1	3.473
75	65	10	5000	199 232 139	1	9.200
90	80	10	7000	199 232 140	1	12.300
110	100	10	11000	199 232 141	1	18.900

d (mm)	D (mm)	H (mm)	H1 (mm)	H2 (mm)	H4 (mm)	H5 (mm)	L (mm)	L1 (mm)	L2 (mm)	L4 (mm)	L5 (mm)	L6 (mm)	L7 (mm)	z (mm)
16	50	159	27	62	40	77	93	194	56	25	261	76	48	67
20	50	159	27	62	40	77	95	194	56	25	261	76	48	66
25	58	168	30	71	40	77	109	194	65	25	261	76	48	77
32	68	168	36	71	40	77	119	194	71	25	261	76	48	83
40	84	202	44	84	51	99	135	224	85	45	305	95	59	99
50	97	202	51	84	51	99	147	224	89	45	305	95	59	105
63	124	225	64	106	51	99	168	224	101	45	305	95	59	117
75	166	262	85	156		70	233		136	70	276	65		167
90	200	281	105	168		78	254		141	70	341	72		180
110	238	292	123	175		86	301		164	120	369	80		215

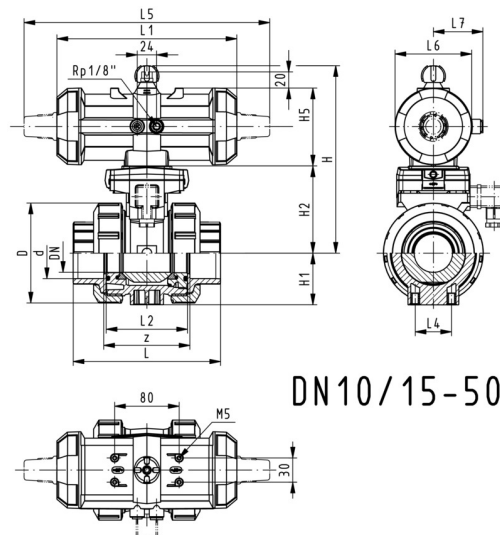

DN10/15-50

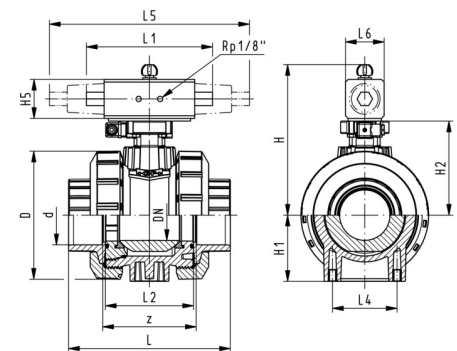

DN65-100